

Self-supplied Wireless Sensor Node Based on MEMS Electret Energy Harvester

Wenjun Zhao, Hiroyuki Fujita and Hiroshi Toshiyoshi

The target of this work is to develop autonomous wireless sensor node powered by MEMS electret energy harvester, with management circuit incorporating power rectification and storage under ultra low power consumption, which would be used in the anomaly detection of air conditioner outdoor unit.

Introduction

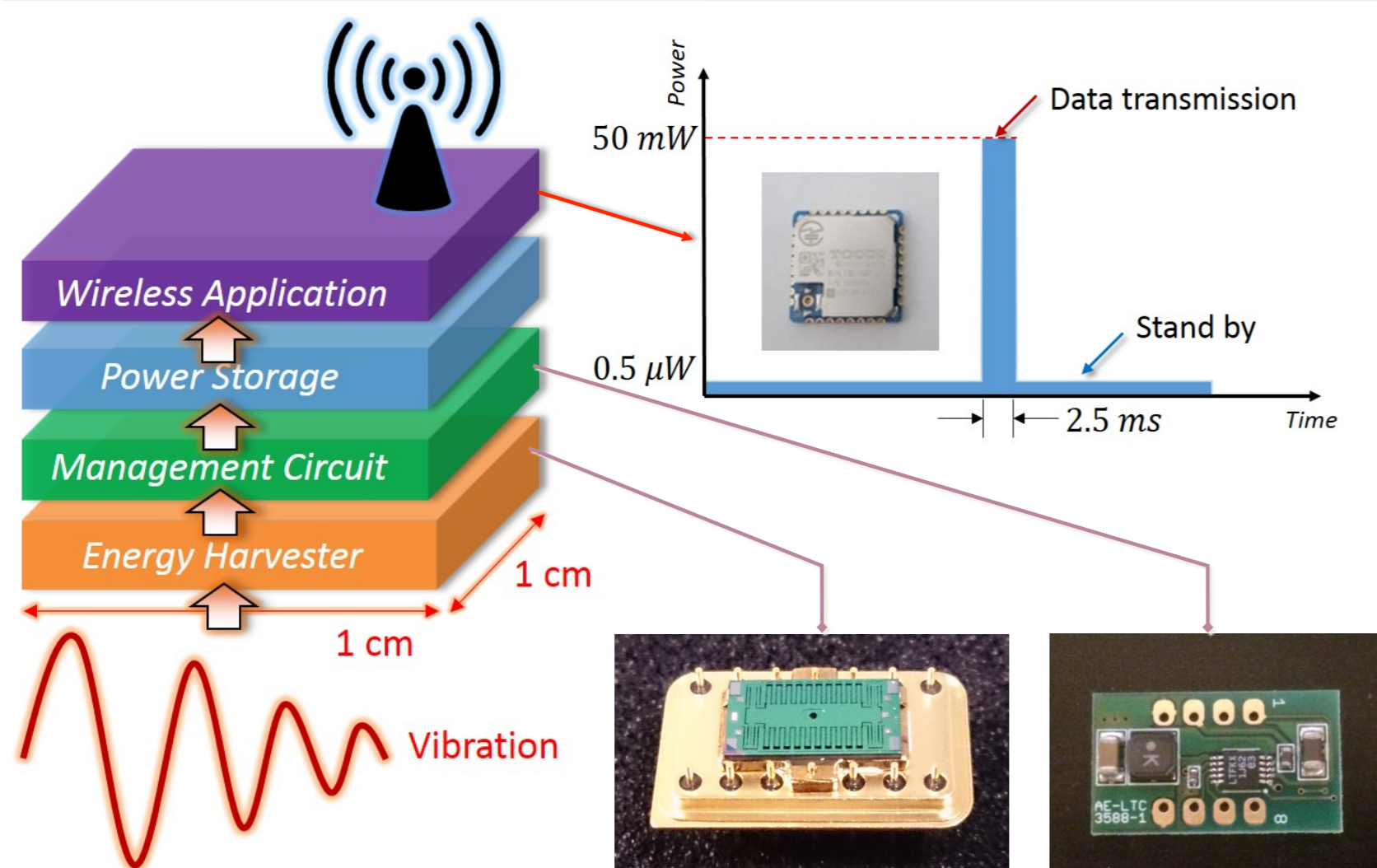

Energy harvesting from ambient sources enables an attractive approach to self-supplied wireless sensor node. MEMS electret EHs have better efficiency than other methods under typical low ambient vibration frequency (<100Hz), which could be expected to drive low power wireless technologies (e.g. Zigbee).

Power management circuit

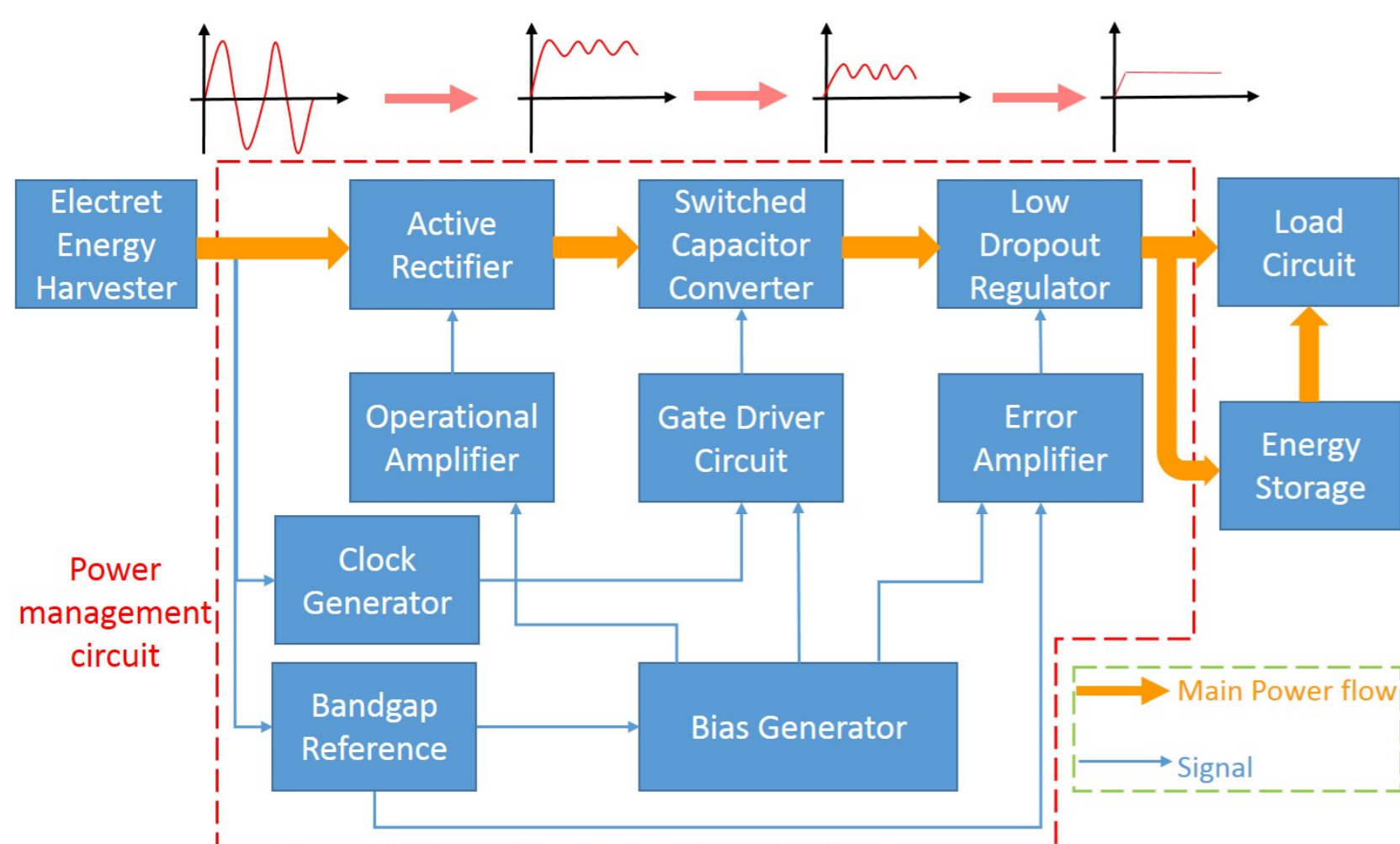

the unpredictable level of ambient sources could not guarantee a stable and constant output from energy harvester.

Power management circuit plays an important role in the total system as the electric interface between energy harvester and wireless chip loads.

Result

We simulate the output from energy harvester by function generator to find whether it's sustainable to power the whole circuit. A stable 3.3V output from power management circuit is available to drive the wireless node.

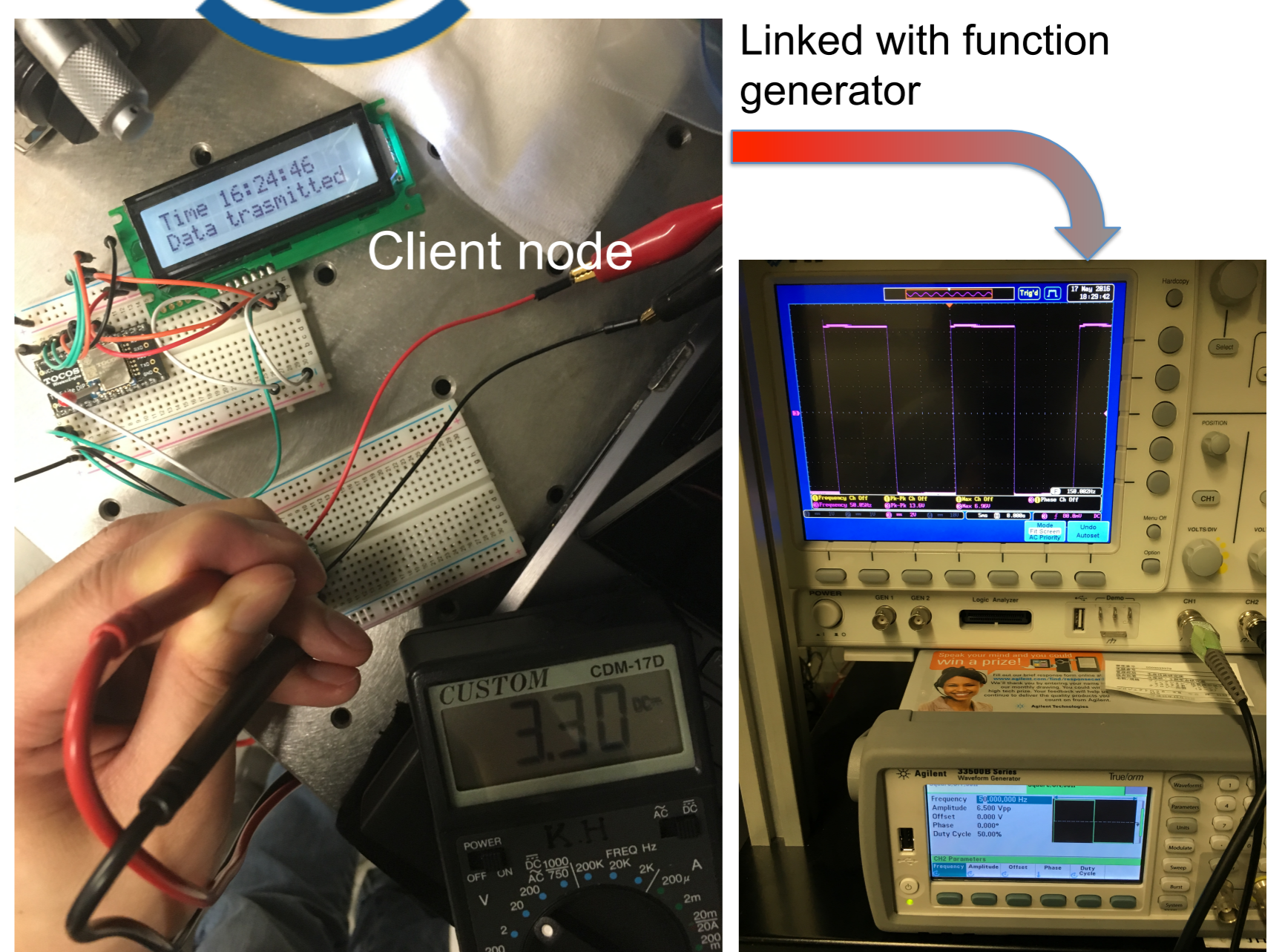
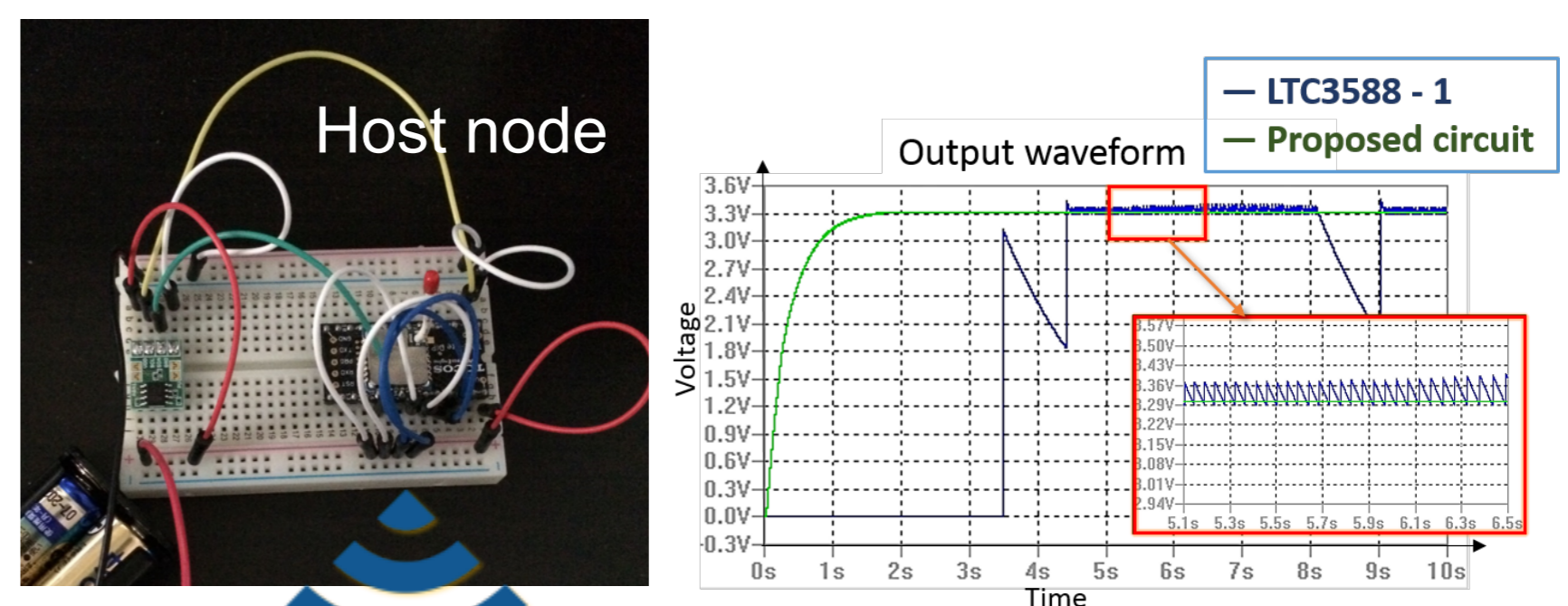

Future work

The power efficiency will be investigated after the integration of the whole wireless sensor node. Especially the impedance matching will be checked carefully to improve the total efficiency of system.

Contact: palemist@iis.u-tokyo.ac.jp